

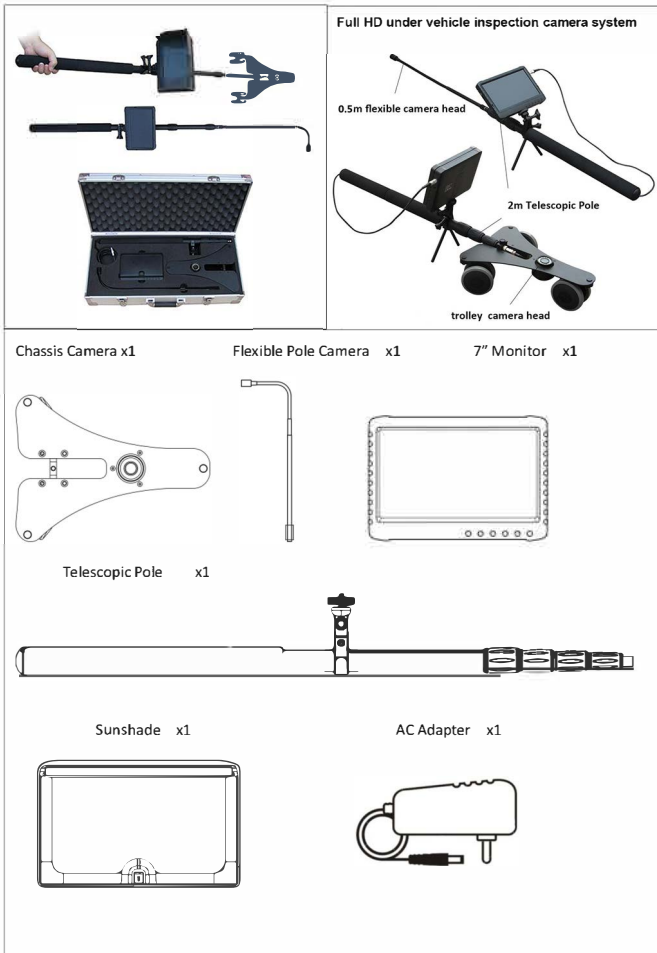

UVS

RMC-UVS-CAM



The Under Vehicle Camera Inspection System is used for screening the under chassis of vehicles. These are typically deployed at the hands of the security at the main gate of a Hotel, Office building, Commercial complex, Shopping Mall etc. to be able to satisfy that the vehicle is clean of any dangerous items viz. explosives etc.

The simple device is popular, easy to use, economical and almost mandatory for securing a premise these days from threats that may be under the chassis of a vehicle. They are alternately also deployed in prisons and certain facilities to block stowaway (movement of unauthorised persons into or out of a facility by hiding under a truck.)

The Camera based system is efficient for use under varied light & climatic conditions. The Tubular flexi camera also aids in a through screening of areas under a vehicle that may be difficult to see or check without a device viz. a simple mirror based reflection gadget.

Accessories

TF card
(8GB) x1



Micro-HDMI cable x1



USB cable x1



DESCRIPTION	PARTICULAR
Make	Ravel Movement Control
Model	RMC-UVS-CAM
Power	12V DC
AC Adaptor	5V
Camera	0.5 Flexible Head
Telescopic Pole	2m
Display	7 inch Monitor
Storage	8 GB MicroSD
Ingress Protection	IP 54



UVS

RMC-UVS-CAM

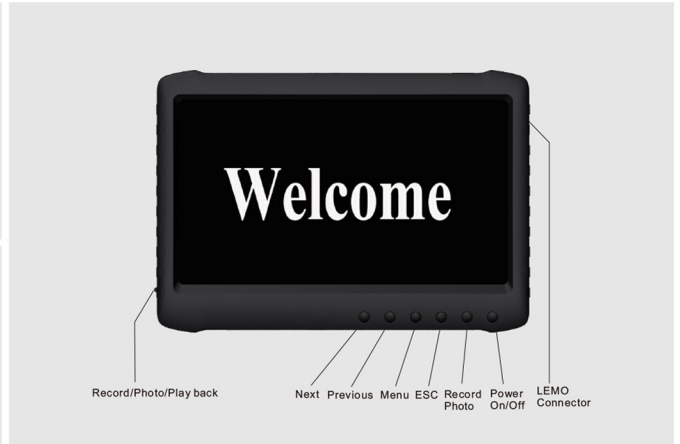
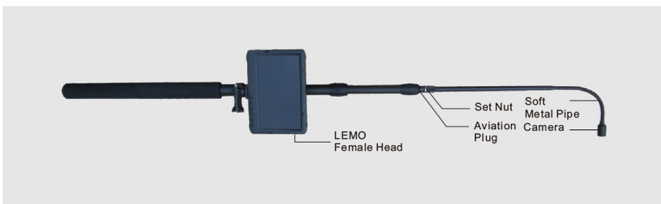
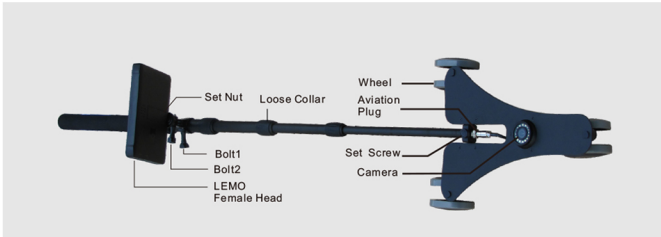
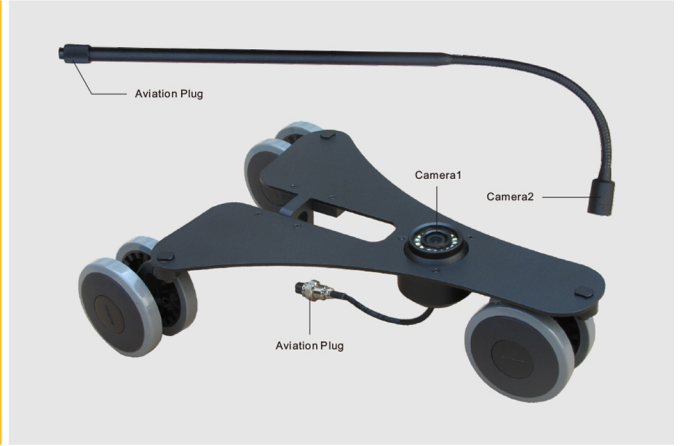
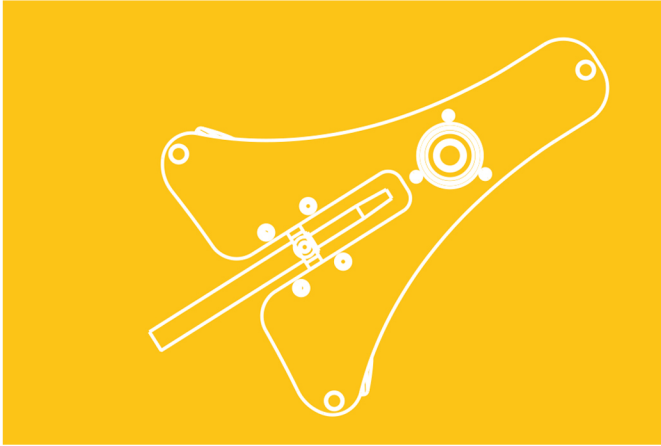

Install the Two Cameras

- > 1" camera: Insert the front end of the telescopic pole into connecting port on the wheel tray. Fasten the set screw. Connect the five core aviation plug of camera to the telescopic pole then fasten the screw.
- > 2" camera (optional) : Insert the flexible pole camera's connector to female head, fasten the nut.

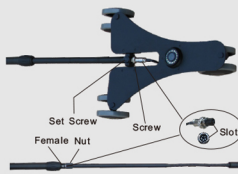

1

Stretch and Retract Telescopic Pole

- > Stretch the pole: Anti-clockwise loosen the loose collars one by one to stretch the pole. Then clockwise fasten the loose collars.
- > Retract the pole: Anti-clockwise loosen the loose collars one by one, then pull out the cable in end of the pole to retract the pole. Clockwise fasten the loose collars.



2

Install the 7" DVR

- > Aim the nut opening on DVR bottom at the screw on pole, and fasten it. Fix the direction & angle by adjusting Set Nut & Bolt 1 & 2.
- > Insert/pull out data line: Just catch the back-end of LEMO jacket and plug it into DVR female slot. When pull out, just catch the movable sleeve and pull it out.

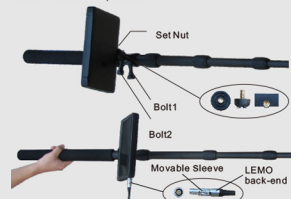

3

Power On/Off & Charge

- > After connection, press to turn on the DVR. Long time press to power it off.
- > When it out of power, please use the DC12V AC adapter or USB 5V to charge it.

Note: (If system halted, please reset it.)

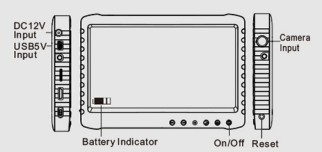

4

Record & Photo

- > Under mode, press , DVR starts to record, and screen shows , press to end record.
- > Under mode, press once, screen flashes once, and get one picture.

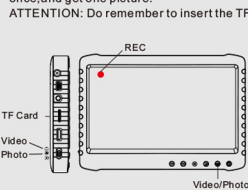

5

Playback Video/Photo

- > Under mode, Press to select the video files or photos, press to playback video or photos.
- > Press to exit.

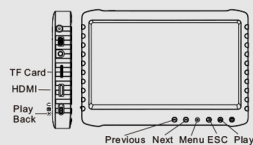

6

Turn On/Off LED lights

- > Press to turn on LED lights, screen shows on.
- > Press again to turn off the LED lights, screen shows off.

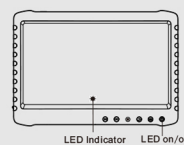

7